



**Automated Tapping Systems**

Manufacturing in-die tapping units for 35 years



# In-die Tapping Solutions

For over 35 years ATS has been the forerunner in the in-die tapping industry, manufacturing the most innovative and reliable tapping units in the world. ATS dedicates 100% of its efforts toward in-die tapping, providing its customers with the cutting edge of technology and engineering support they can count on. When implementing in-die tapping, our engineers have a vast variety of tapping units to work with, including top-down, bottom-up, high-speed, strip-following, 90-degree, servo, servo-strip-following, and multi-spindle. ATS customers know they will have the most competitive and cost effective solution to in-die tapping available.

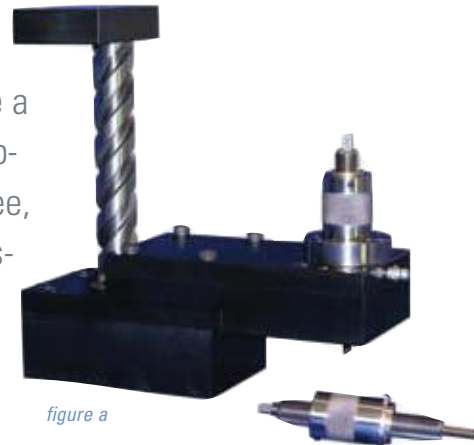

figure a

## Reliable

Over 35 years of manufacturing experience gives ATS an engineering foundation unequaled in the industry. ATS in-die tapping units are capable of running millions of maintenance-free parts. Reliability is only one reason we are often called upon to replace a competitors' tapping unit with an ATS tapping unit.

## Innovative Design

ATS' tapping units are not only designed to be the most rugged in the industry; they have many user-friendly features that make them favored among tool shops around the world. ATS' twist-lock lead-screw assembly allows tap changes, pitch changes, and tap height adjustments to be made in seconds; —all without removing the tapping head. We can design multi-spindle tapping units, strip-following tapping units, bottom-up tapping units with all the same features, requiring very little die space, as is evident in the eight-spindle tapping unit pictured.

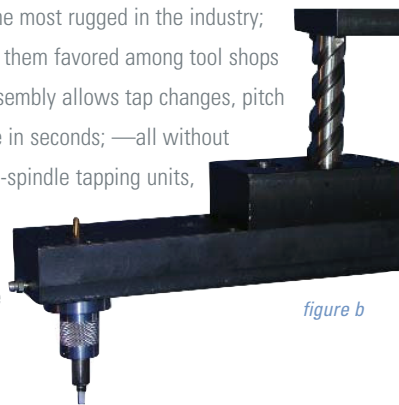

figure b

## Cost Effective

ATS tapping units are not only innovative and durable, they are also the most cost-effective, user-friendly tapping units available. When quoting a job using ATS tapping units, our customers have a distinct advantage over the competition.

## Top-Down (figure a)

Top-down tapping units are ideally adapted to parts, with minimal strip lift. These units are capable of running very high speeds and ideally suited to high volume jobs, while requiring minimal maintenance. They utilize twist lock lead-screw assembly, allowing tap changes to be made in seconds.

## Bottom-Up (figure b)

When strip lifts increase beyond the capacity of standard top down tapping units, tapping from the bottom up is the more desirable method. Bottom-up tapping units are capable of running at speeds similar to top down tapping units for millions of virtually maintenance free strokes.

## Multi-Spindle Units (figure c)

These units are used to tap eight holes, for an automotive part, in a single station. Multi-Spindle units are the most cost-effective per hole-tapped method of in-die tapping. They greatly reduce die space, as compared to individual tapping units.

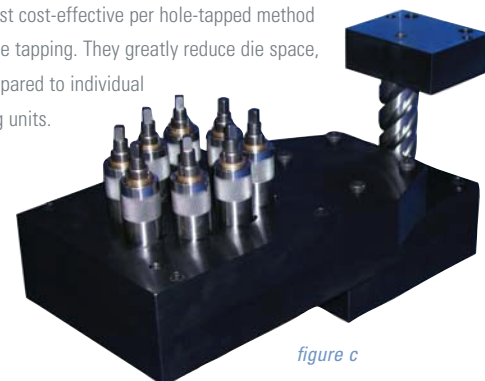

figure c

## FEATURES

- Press speeds up to 250 strokes per minute
- Uses standard-cut or roll form taps
- Simple installation saves tooling costs
- Removable twist-lock lead screw assembly
- Change tap in seconds
- Change tap size and pitch in only minutes
- Misfeed protection prevents tap breakage
- Through-tool coolant capabilities
- High-torque driver
- Capacity 2-56 to 1 1/4"-12 (or metric equivalent)
- Change from die to die in minutes
- Lead-screw tapping assures quality thread
- Custom units built to customer's specs

### Strip Follower (figure d)

The self-contained strip-following tapping units increase tapping production rates while maintaining standard strip-per travels, greatly reducing tooling costs.



figure d

### Multi-Spindle Strip Follower (figure e)

The tapping unit shown is a compact eight-spindle, strip-unit built for an electrical manufacturer to tap eight holes in a single station. Note: this unit uses a twist-lock lead-screw assembly, allowing tap changes to be performed in seconds.

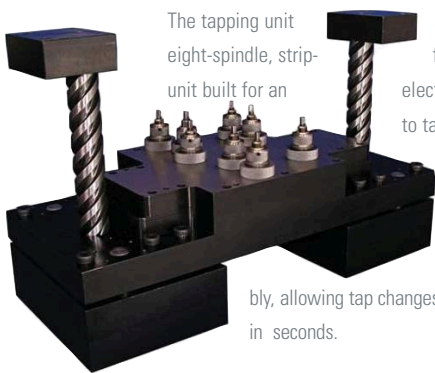

figure e

### Servo Driven (figure f)

The threading operation of a servo-driven tapping unit functions independently of the press stroke, which is particularly useful with larger diameter taps. The tapping unit pictured is a universal servo-driven unit, capable of tapping from the top down or bottom up.



figure f

## ATS PATENTED TECHNOLOGY



### Twist-Lock Design

ATS' twist-lock lead-screw assembly has many unique features incorporated into a very compact unit. With our lead-screw assembly, tap changes are made outside the die. This is not only safer, but faster and easier for the operator. Tap adjustments are made easily by simply changing the starting point of the twist-lock lead-screw assembly to the appropriate height without removing the tapping unit. This is unique to all ATS tapping units and simplifies set-up from job to job.

### Strip-Following Technology

The ATS strip-follower unit increases tapping production rates by 50% or more, while maintaining standard stripper-travel lengths. Lower stripper travel translates into lower tooling costs. The SF unit allows for a larger tapping window during the press cycle, allowing tapping head gear ratios to be reduced. In turn, it increases the strokes per minute that the press can run and still maintain the proper RPM on the tap. The result: an increase in production of 50% or more!

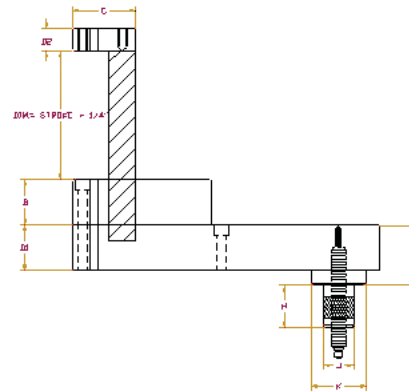
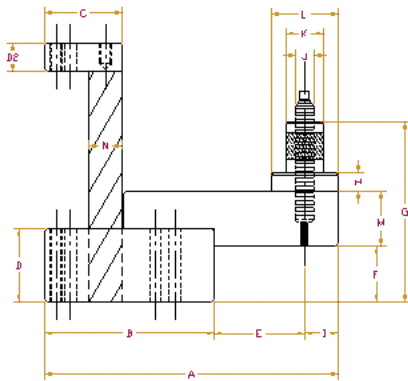
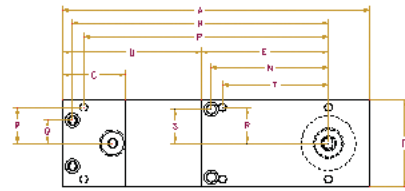
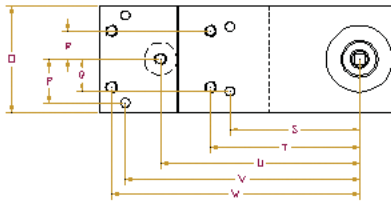

	TH25	TH35	TH45
A	7.915	8.415	11.550
B	4.575	4.575	7.000
C	2.185	2.185	3.000
D1	2.000	2.000	2.000
D2	0.750	0.750	1.500
E*	2.440	2.440	2.900
F	1.500	1.500	2.350
G	4.875	5.375	8.225
H	0.500	0.500	1.000
I	0.900	1.400	1.625
J	0.500	0.625	0.750
K	1.000	1.250	1.625
L	1.800	2.000	2.700
M	1.500	1.500	2.500
N	0.875	0.875	1.375
O	2.875	2.875	4.000
P	1.185	1.185	1.750
Q	0.875	0.875	1.309
R	0.760	0.760	1.250
S	3.500	3.500	4.783
T	4.025	4.025	5.408
U	5.375	5.375	7.471
V	6.325	6.325	8.908
W	6.700	6.700	9.471

	TH25	TH35	TH45
A	10.125	10.125	13.450
B	1.500	1.500	1.500
C	2.075	2.075	3.125
D1	1.500	1.500	1.500
D2	0.750	0.750	1.500
E	4.187	4.187	4.808
F	2.875	2.875	4.000
G	2.000	2.000	—
H	1.375	1.875	2.470
J	1.000	1.125	1.161
K	1.800	1.900	—
L	0.875	0.875	1.375
M	8.450	8.450	11.371
N	3.875	3.875	4.308
O	7.125	7.125	9.371
P	8.074	8.074	10.808
Q	0.760	0.760	1.250
R	1.185	1.185	1.750
T	—	—	3.758
U	4.575	4.575	7.000

\* Longer Lengths Available

## Don't just take our word for it — see what some of our customers have to say!!!

"We've used ATS tapping units for the last 20 years, finding service & customer support to be exemplary. We've found the latest generation of ATS units to be the most compact, durable and designer-friendly we've experienced."

**Hakiem Kahn, Tooling Engineer, Tryco Tool & Mfg. Co., Inc.**

"After switching from a competitors tapping unit to an ATS unit, we've run millions of parts and substantially reduced maintenance & operating costs. We have since converted all our tapping dies to ATS tapping units."

**Sam Valente, Mulberry Metals, Inc.**

"After experiencing an alarming number of failures with a competitor's tapping unit, we mounted an ATS unit in one of our existing tapping dies. With the ATS tapping unit, we were able to increase our per-tap numbers from 30,000 to 90,000 parts per tap and were able to use standard taps priced at \$8.00 each, compared to custom taps priced at \$30.00 each. We have run in excess of 50,000,000 pieces, lowering maintenance and operating costs to a small fraction of what they were."

**Paul Mounter, American Engineered Components, Inc.**

"We looked at all the in-die tapping options available, and only one could meet our specifications. We bought that first 2-spindle ATS unit in 1996, and it paid for itself within the first year. We were so pleased with those savings and the unit's flawless performance that we have purchased thirteen more units since then, with one, two, three, and five spindles. We currently have eight progressive dies in use with eleven "bottom up" tappers and three "top-down" units, tapping up to 6,000,000 pieces per spindle per year."

**Major US Electrical Manufacturer**

"After manufacturing a particular part with a tapped hole for a number of years, our customer demanded cost reductions to eliminate the risk of losing the job to overseas competition. Since the secondary tapping operation was more costly than the stamping operation, we contacted ATS to explore the possibility of in-die tapping. The engineers at ATS assured us that our part was an excellent candidate for in-die tapping. They followed through from design to the initial installation of the unit. We lowered the cost to our customer, increased quality, and increased our profits through in-die tapping. We have run over 6,000,000 trouble-free parts in our first eight months and wish we had twenty presses running similar jobs."

**Mark Ericson, J & J Precision Eyelet**

"With the success of our first couple of ATS tapping units, we contacted ATS, to examine and retrofit a part previously thought not-to-be-feasible for in-die tapping. The engineers at ATS designed and built a 4-spindle-strip following tapping unit which required few modifications to our existing tool. Without sacrificing press speed, we were able to combine stamping and tapping into a single operation, eliminating the need for costly secondary tapping."

**Frank Dietrich, Northfield Metal Product**



DANLY Deutschland GmbH  
Daimlerstr. 29  
D-78083 Dauchingen  
Tel.: +49 7720 9723 0  
Fax: +49 7720 9723 50  
E-mail: [info@danly.de](mailto:info@danly.de)

Distributed by:

